

VM Models

Vertical Core / Remote Mount / Direct Motor Driven Fan

Genset Application

Remote mounted, vertical core radiator designs with fan and electric motor. Ideal for cooling a wide range of diesel or gas engine powered gensets from 100 kW to 400 kW.

Superior Durability

High strength mechanical-bond core and exclusive O-ring tank seals provide unmatched reliability and durability.

Configurator System

Our configurator process combines flexibility and standardization with speed. Radiator designs are optimized and assembled with pre-engineered components in short lead-times.

Product Performance

Our product line offers a wide range of core face areas, row counts, fan drives, finish coatings and structural options. These radiators perform in the most difficult generator set installations and environments.

Technology

Young Touchstone developed the industry's leading application engineering software to deliver quick and accurate cooling solutions. Lean manufacturing principles eliminate waste, improve quality and reduce cost.

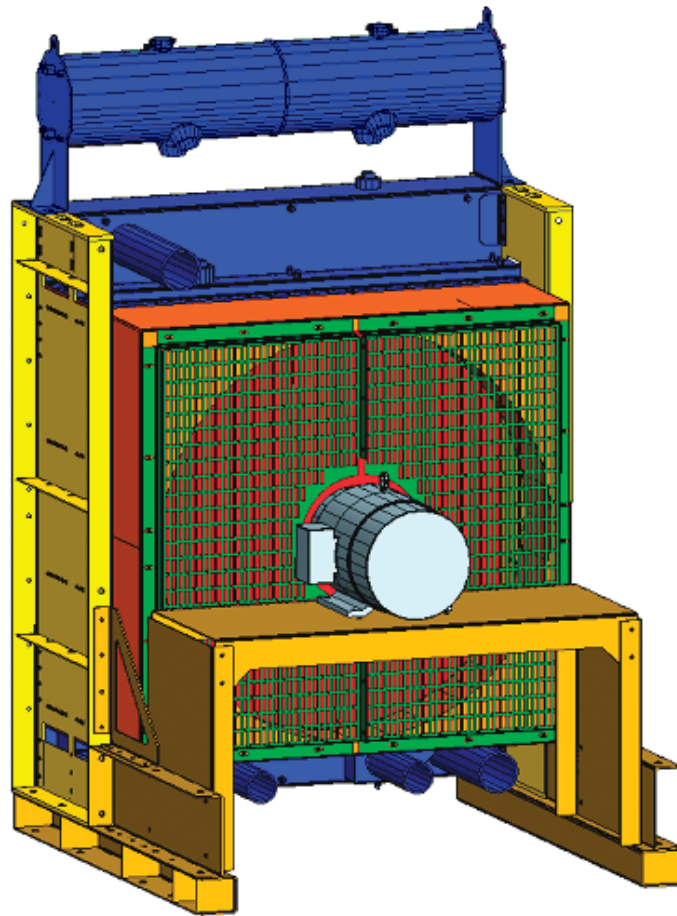

VM Models

Vertical Core / Remote Mount / Direct Motor Driven Fan

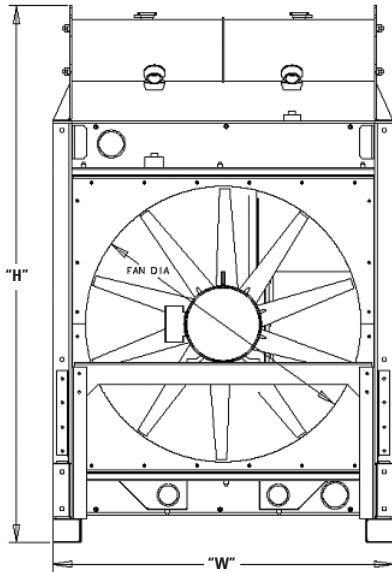

VM Models Technical Data Table

Model	Max. W (in)	Max. H (in)	Max. D (in)	Max. Weight (lbs)*	Max. Volume (gal)*	Max. Fan Dia. (in)
04	34	68	48	875	27	24
06	39	71	48	970	33	27
08	42	76	55	1,338	37	32
10	47	80	56	1,494	44	36
12	51	84	56	1,593	50	40
15	56	88	59	2,001	56	44
19	61	95	59	2,210	67	48

* Includes Surge Tank Weight and Volume

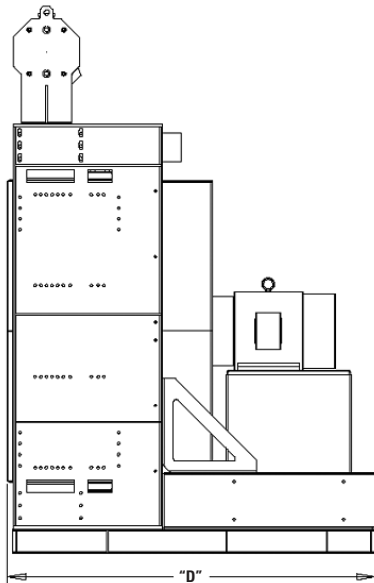

For additional information about our products, please contact Young Touchstone or your local Young Touchstone sales representative.



2825 Four Mile Road, Racine, WI 53404-1005 • Phone: 262.639.1010 • Fax: 262.639.1013