

9800AD Series

UNINTERRUPTIBLE POWER SUPPLY SYSTEMS

100/150/225/300/375/500/750kVA
SINGLE AND MULTI-MODULE SYSTEMS



**Where Reliability
Breeds Confidence**

**ISO 9001
CERTIFIED**

 **MITSUBISHI ELECTRIC**

Reliability and Flexibility

Today's business climate requires UPS Systems that offer not only Reliability but also Flexibility. Mitsubishi Electric Multi-Module Systems (MMS) utilize UPSs with independent parallel control and bypass circuits, and a unique Critical Load Cabinet (CLC) to offer complete System Reliability and Flexibility.

Parallel control circuitry, system static bypass and control circuitry reside in each individual Multi-Module System UPS, optimizing control redundancy and eliminating common control single points of failure. This results in highly reliable system architecture.

For many installations, System Expansion with the addition of UPS modules is required if future load demand becomes apparent. For most MMS available today, the reverse scenario of System Reduction with the capability of utilizing the removed UPS module is not possible without UPS module modification. With the Mitsubishi Electric MMS, not only System Expansion but also System Reduction is possible, with the capability to utilize the removed UPS module for Single Module System (SMS) applications, because each UPS module has independent static bypass and control circuitry. This System Expansion and Reduction results in a highly flexible system configuration.

**Superior Performance,
Reliability and
Safety Come from
Experience.
Our Uninterruptible
Power Supply
Multi-Module Systems
Ensure All Three.**



Mitsubishi Electric IGBT
(Insulated Gate Bipolar Transistors)

Mitsubishi Electric has been developing and manufacturing Uninterruptible Power Supply (UPS) Systems and components for nearly four decades. This experience and the continuous application of new power device technologies to further improve products and their specifications, clearly explain why Mitsubishi Electric has dominated a large portion of the world UPS market for years.

SMS and MMS UPS Modules

IGBT – Excellent Performance Characteristics

Mitsubishi Electric is the leading manufacturer of Insulated Gate Bipolar Transistors (IGBT). IGBTs are utilized in the 9800AD Series UPS Systems. These advanced, high-performance transistors provide a variety of intelligent features:

- Large power capabilities
- High speed switching
- Low control power consumption

Low Input Current Harmonics (THD)

- 6% Typical (100% Load)

Heat Loss/High Efficiency

Use of IGBTs for the Inverter permits efficient switching speed (2kHz), thus reducing heat dissipation in the UPS. (Higher efficiency means lower cost per kilowatt to the customer.)

Operator-Friendly Control Panel

Features:

- Mimic flow diagram
- Operator control station
- Touch panel input

LCD Monitor:

- UPS metering
- Voltage/Current/Power status levels
- Simple start/stop operation
- History of events

Critical Load Cabinet (CLC)

- Independent Static Bypass Switch Circuit within each UPS module
- Independent Parallel and Static Bypass Control Circuitry within each UPS module – Elimination of common control single points of failure
- System Maintenance Bypass Circuit with Electrical Mechanical Interlocks as standard
- UPS MMS monitoring system

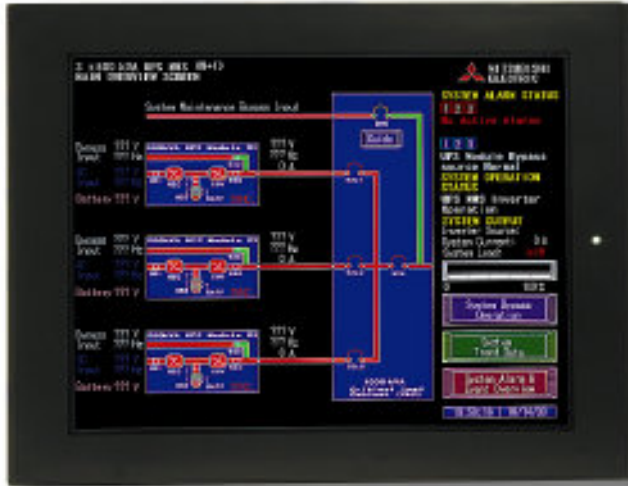

CLC Monitoring System Features

- Monitors complete UPS Multi-Module System
- Utilizes Ethernet and 10BaseT
- Touch screen operator terminal
- MMS mimic flow diagram and color status display
- MMS UPS module metering
- System Voltage/Current/Power Measurement displays
- Individual UPS module and battery data screen
- System event and alarm screens
- Alarm history screens
- Remote web monitoring
- Trend data screens
- Operator function screens
- High communication capability

UPS Module KVA Capacity

- 100, 150, 225, 300, 375, 500 and 750kVA Modules

Standard Features

- UL1778/cUL, UL891 approved
- IGBT
- Conformally coated boards (industrial environment)
- Front access only (serviceability)
- “DiamondSense” battery self-test

MMS Features

- Parallel redundant or capacity system configuration
- MMS Capacity: Up to 8 UPS modules in parallel
- Instantaneous equal load sharing
- Individual UPS modules can be removed from an on-line system for maintenance.
(Note: redundancy will be lost)
- System maintenance bypass as standard
- System load bank test circuit (optional)
- System flexibility
- Central system monitoring system

Battery DC Link

- 480V DC

Operating Environment

- Low acoustic noise
- Temperature: 0~40°C
- Relative humidity: 5~95% (non-condensing)
- Altitude: 0-9,000 feet (no derating)

AC Input Rating

- -15% ~ +15%
- Power: Rated kVA at 1:1.1 ratio
- 480 VAC (600 VAC using input transformer)
- THD (reflected current):
6% typical (100% load)
9% typical (50% load)
- 3-phase, 4-wire, plus ground (Bypass: 4-wire, Rectifier: 3-wire)
- Frequency: 60Hz (±5%)
- Surge withstand:
Meets IEEE C62.41-1991

AC Output Rating

- 480Y/277 VAC or 600Y/347 VAC
- 3-phase, 4-wire, plus ground
- Output power factor rating:
(100-225kVA) 0.8~1.0 Lag (within output kW rating)
(300-750kVA) 0.9~1.0 Lag (within output kW rating)
- Frequency: 60Hz (±0.05%) (free running)
- Voltage accuracy: ±1%
- Transient recovery time:
Less than 20 ms
- Load unbalance:
100% ±1% or less
- Step load change: 0~100% ±2%
- Load/Return of AC power:
±1% (at 100% load)
- UPS load transfer, bypass:
±5% (at 100% load)
- THD (voltage): 2%
(100% linear load); 5%
(100% non-linear load)

One-Line Diagram

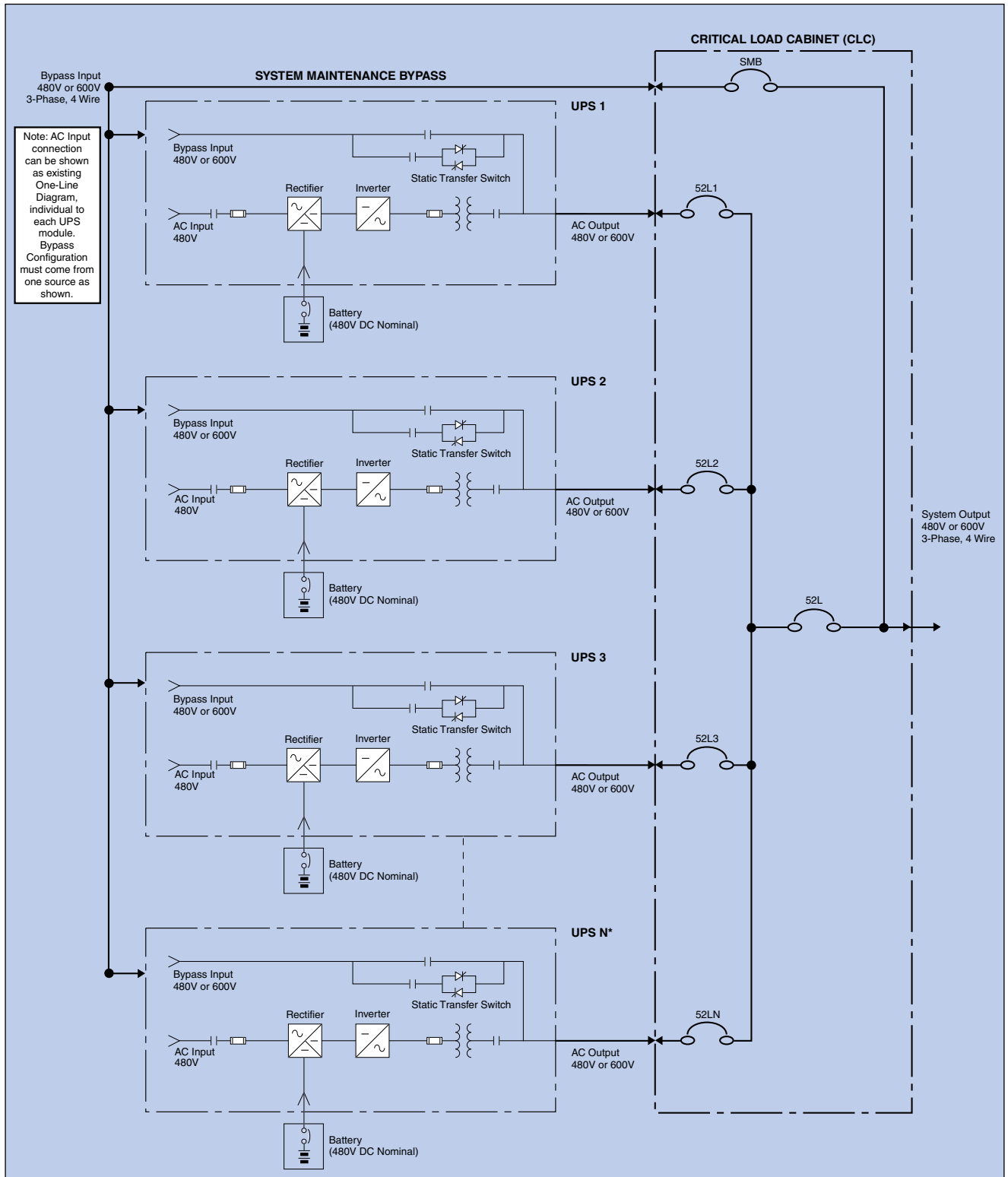

*Up to 8 UPS modules (of same capacity) can be paralleled together in an MMS.

Specifications

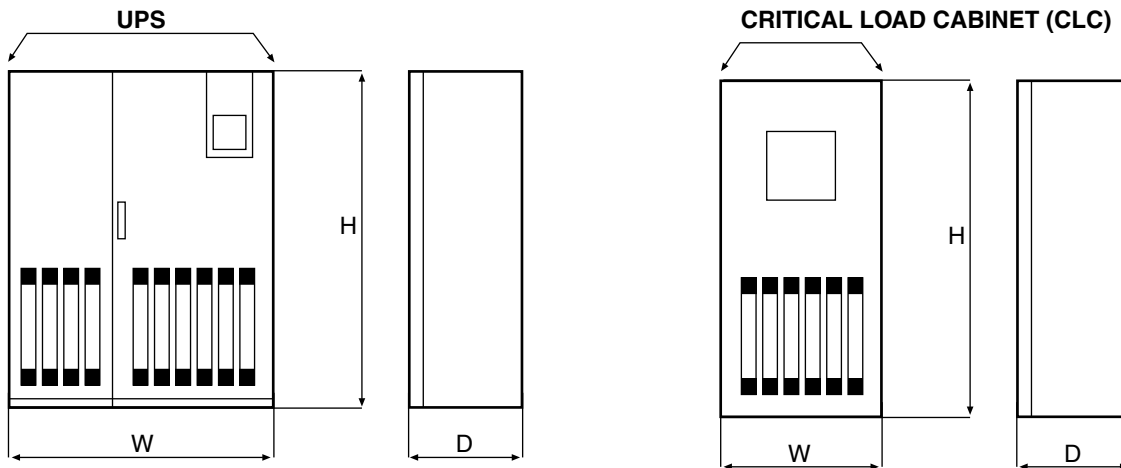

Basic MMS System Dimensions

kVA/KW	Dimensions (W x D x H) (in)	Weight (lbs)	Comments
100/80	43.3 × 29.9 × 79.7	1,970	Shipped in (1) section
150/120	47.2 × 29.9 × 79.7	2,480	Shipped in (1) section
225/180	55.1 × 29.9 × 79.7	3,160	Shipped in (1) section
300/270	76.8 × 37.8 × 79.7	4,277	Shipped in (1) section
375/337.5	76.8 × 37.8 × 79.7	4,718	Shipped in (1) section
500/450	114.2 × 37.8 × 79.7	7,175	Shipped in (2) sections
750/675	129.9 × 49.5 × 79.7	9,655	Shipped in (2) sections



FOR CRITICAL OPERATIONS

Standard Critical Load Cabinet (CLC) Dimensions (Estimated)

kVA	2 x MMS		3 x MMS		4 x MMS	
	(W x D x H) (in)	Weight	(W x D x H) (in)	Weight	(W x D x H) (in)	Weight
100	54 × 29.9 × 79.7	2,000	84 × 29.9 × 79.7	3,000	84 × 29.9 × 79.7	3,050
150	54 × 29.9 × 79.7	2,000	84 × 29.9 × 79.7	3,000	90 × 29.9 × 79.7	3,100
225	54 × 29.9 × 79.7	2,100	90 × 29.9 × 79.7	3,100	90 × 29.9 × 79.7	3,250
300	54 × 37.8 × 79.7	2,100	90 × 37.8 × 79.7	3,100	90 × 37.8 × 79.7	3,400
375	60 × 37.8 × 79.7	2,200	90 × 37.8 × 79.7	3,250	95 × 37.8 × 79.7	3,500
500	60 × 37.8 × 79.7*	2,300	94 × 37.8 × 79.7*	3,400	99 × 37.8 × 79.7*	4,300
750	97 × 50.1 × 79.7*	4,100	99 × 50.1 × 79.7*	4,300	120.6 × 50.1 × 98.9*	7,900

* Sizes will change dependent on capacity/redundancy type configurations
For systems 5x and above, please consult the Mitsubishi Engineering Department

- High Reliability – Independent Parallel and Static Bypass Control Circuitry
- High Speed – Digital Signal Processor (DSP) Applied Direct Digital Control (DDC) Calculation and Control
- Stable Operation – Instantaneous Equal Load Sharing Control

9800AD Series

UNINTERRUPTIBLE POWER SUPPLY SYSTEMS

100/150/225/300/375/500/750kVA
SINGLE AND MULTI-MODULE SYSTEMS

Corporate Headquarters:

Mitsubishi Electric Automation, Inc.
500 Corporate Woods Parkway
Vernon Hills, IL 60061
Phn: (847) 478-2100
Fax: (847) 478-2253
www.meau.com

Mitsubishi Electric Automation, Inc.
4299 14th Avenue
Markham, Ontario L3R 0J2
Phn: (905) 475-8989
Fax: (905) 475-7935



The quality management system of
Mitsubishi Electric Corporation Kobe Works
has been approved to ISO9001:1994.

The quality management system is
applicable to design, development and
manufacturing of the UPS.

Printed with soy inks 

L-VH-08229 Printed in USA
Effective December, 2003
Specifications and products offered
subject to change without notice.