

## Transformerless UPS systems and the 9900

By: John Steele, EIT  
Engineering Manager

### Introduction

There is a growing trend in the UPS industry to create a highly efficient, more lightweight and smaller UPS system. Data Centers across the world are constantly searching for new ways to maximize reliable UPS power while minimizing the UPS and associated equipment footprint. In addition, operating costs for large data centers always will be a priority.

In applications which require a smaller capacity UPS (less than 200 kW), true on-line double conversion transformerless UPS systems have emerged as the topology of choice. In larger applications, most UPS systems consist of a UPS with a transformer, or multiple smaller UPS power modules paralleled together to achieve the required capacity. Most UPS manufacturers are finding it difficult to create a true on-line double conversion transformerless UPS system larger than 200 kW due to factors such as ground faults, high frequency noise and efficiency.

Transformerless UPS systems utilize Insulated Gate Bipolar Transistor (IGBT) for all power conversion processes (AC/DC converter, DC/DC chopper and the DC/AC inverter). IGBTs are much faster than the traditional thyristor and can be controlled by simply toggling an on/off gate signal using a digital signal processor and a field programmable gate array as opposed to waiting for a zero crossing. When the gate signal is removed, the IGBT turns off. The combination creates a series of pulses to re-shape existing voltages (conversion from AC to DC and from DC back to AC).

As with any switching power electronic, the device itself has power losses. For the IGBT, the two primary losses are the conduction losses and the switching losses. Since the IGBTs are being turned on and turned off much faster, the switching losses will increase creating a less efficient system. This is a challenge most manufacturers have been unable to overcome in larger capacity UPS systems.

For this reason, many UPS manufacturers will still use thyristors as opposed to IGBTs in the converter section of the UPS (rectifier section). Although there are many benefits in using IGBTs in the converter section, a decrease in efficiency prevents this from being a preferred option for most in larger UPS kW rated systems (above 200 kW). In the UPS inverter, the benefits of the IGBT switching speed have far outweighed the decrease in efficiency.

It is important to note that a transformer serves many purposes in the UPS system. Even if the UPS utilizes IGBTs for switching, a transformer would still have a purpose. Other technologies such as the IGBT switching controls and fault detection still need to be considered.

This paper will discuss the new technologies used in transformerless UPS systems and the advances in the Mitsubishi 9900 series UPS systems.

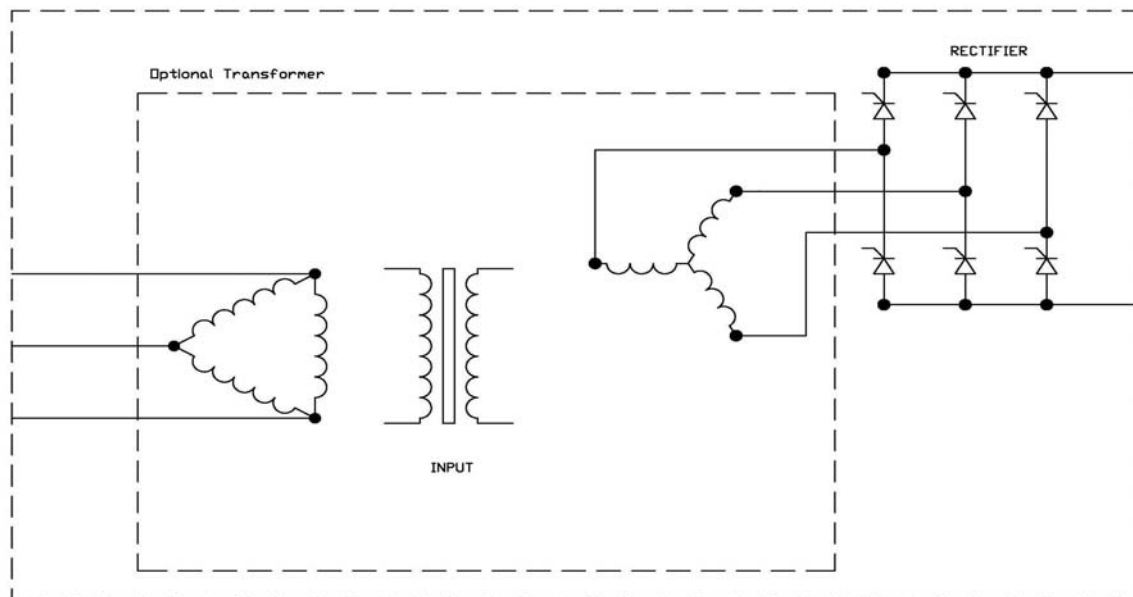
## Background

Before the advances in UPS controls and the benefits of the IGBT in the converter and inverter can start to be appreciated, the primary and secondary purposes of the transformer in traditional UPS systems must first be discussed.

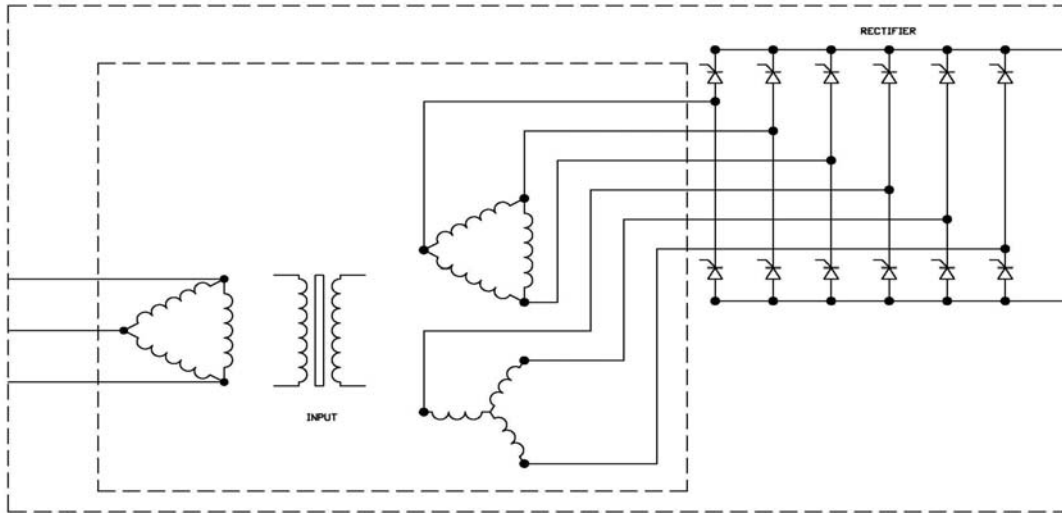
### Converter Section:

The main purpose of the converter section of the UPS is to convert the AC utility power to DC power. The most popular power electronics used for this process are the Diode (6 pulse), the thyristor (SCR 6 pulse and SCR 12 pulse) and the IGBT. Until recently, the 6 pulse and the 12 pulse SCR rectifier have been the most popular.

As shown in figure 2, the 12 pulse SCR rectifier uses an isolation transformer in combination with two 6 pulse SCR rectifiers (figure 1 shows a 6 pulse SCR rectifier). The 30 Degree phase shift provided by the transformer is the main purpose of the isolation transformer. The two 6 pulse SCR rectifiers will alternate to create twice as many pulses. The 12 pulse SCR rectifier will produce fewer harmonics than the single 6 pulse SCR rectifier allowing for a smaller harmonic filter.

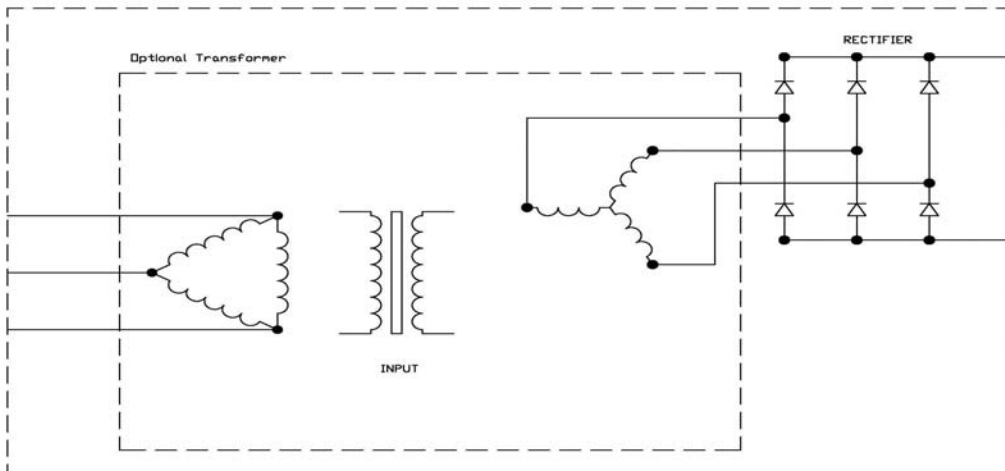


**Figure 1: 6 pulse rectifier with optional transformer**

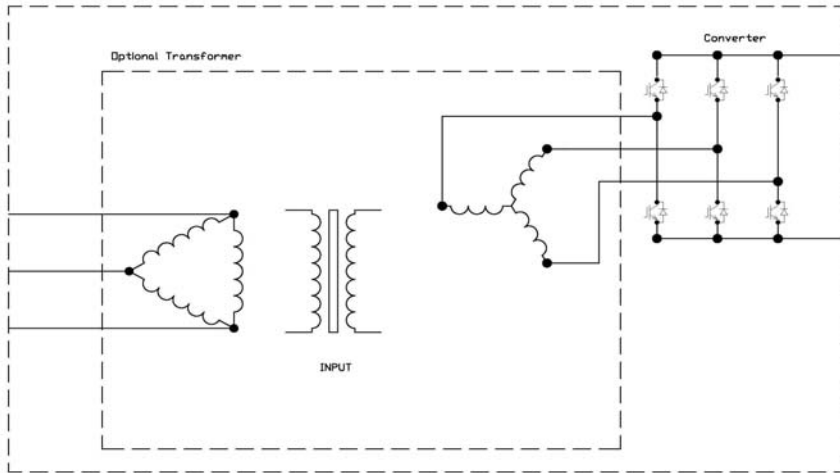


**Figure 2: 12 pulse rectifier with optional transformer**

The Diode bridge converter (figure 3) is similar to the 6 pulse SCR rectifier, except the Diodes are natural commutation (natural on and natural off). The benefits of the Diode bridge are better efficiencies and lower harmonics compared to a traditional SCR rectifier.

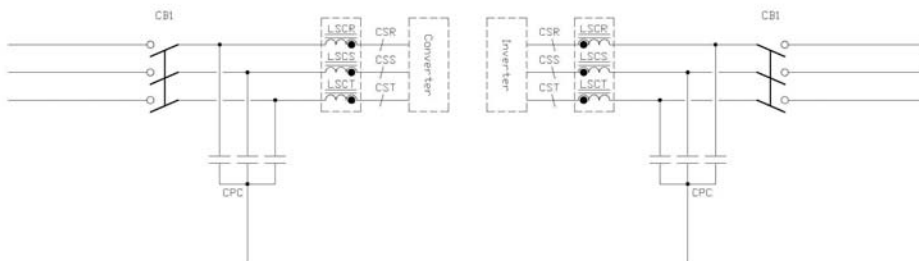


**Figure 3: Diode Bridge rectifier with optional transformer**

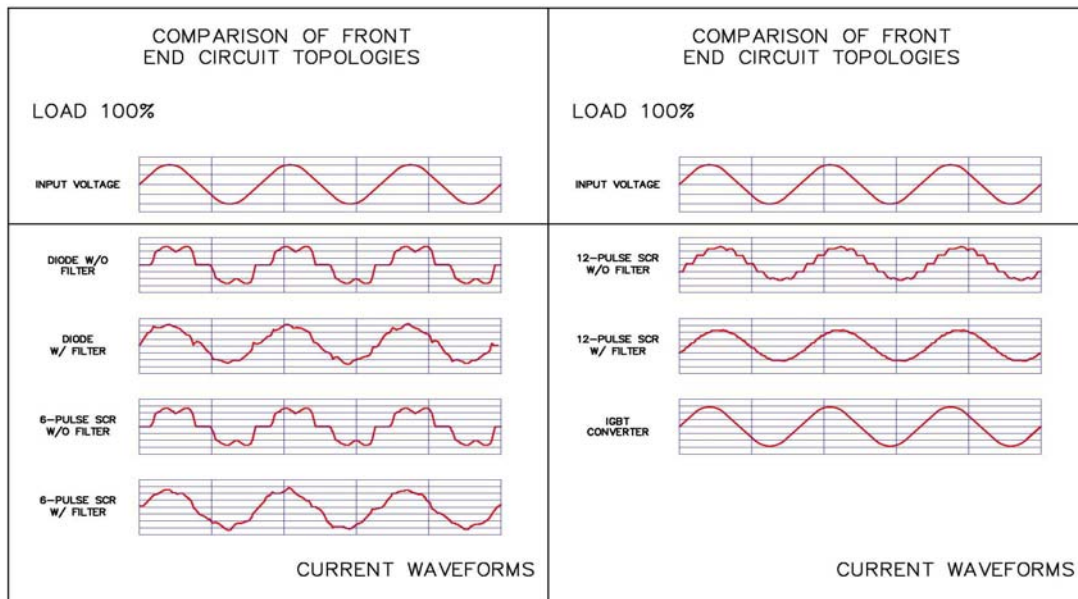


**Figure 4: IGBT Converter with optional transformer**

Every rectifier, regardless of the technology or power electronics used, will produce harmonics. For all technologies but the IGBT (figure 4), these harmonics are greater than desired for most electrical systems, including the backup generator. Therefore, an input filter is required to reduce the harmonics to less than 10%  $i_{THD}$ . As shown in Figure 5, the input filter is comprised of an inductor with a parallel capacitor. The transformer, in this case, helps add inductance to the line to further reduce the harmonics. Figure 6 shows reflected harmonic distortion on input current waveforms from their respective rectifier or converter technology.



**Figure 5: Filters for the rectifier section (Left) and inverter section (Right)**



**Figure 6: Input current harmonic comparison**

Finally, the isolation transformer used in the converter section of the UPS system will provide isolation between the UPS module and the utility. This isolation helps protect against DC ground faults caused by the batteries and will minimize damage to the upstream distribution system due to a separation in the transformer input and output windings.

Although some manufacturers have started using IGBTs in the converter section, most are still switching the IGBTs based on the traditional SCR logic. The benefit of using a slower switching speed for the IGBT converter is a higher efficiency (less switching means less switching losses). In this case, the IGBT converter will still produce larger amounts of harmonics, which will require the input harmonic filter (similar to the harmonic filter for the SCR rectifiers).

The problem with traditional harmonic filters on the UPS converter is the leading power factor at small loads. When the UPS system is operating at a reduced load, the ratio of capacitance in the input filter to the load becomes very large and will produce a leading power factor from the UPS. This leading power factor can result in generator compatibility issues. To eliminate these issues, an active input filter (switching harmonic filter capacitors in and out of the circuit depending on the load) will need to be used or the input filter would need to be disconnected both resulting in an increased harmonic content.

**Digitally controlled IGBT converters:**

IGBT converters offer many benefits over SCR type rectifiers if applied correctly (see figure 4 above). The IGBT converter can switch at speeds in the kilo-hertz range as opposed to the slower SCR rectifier, which fires pulses in the hundreds-hertz range.

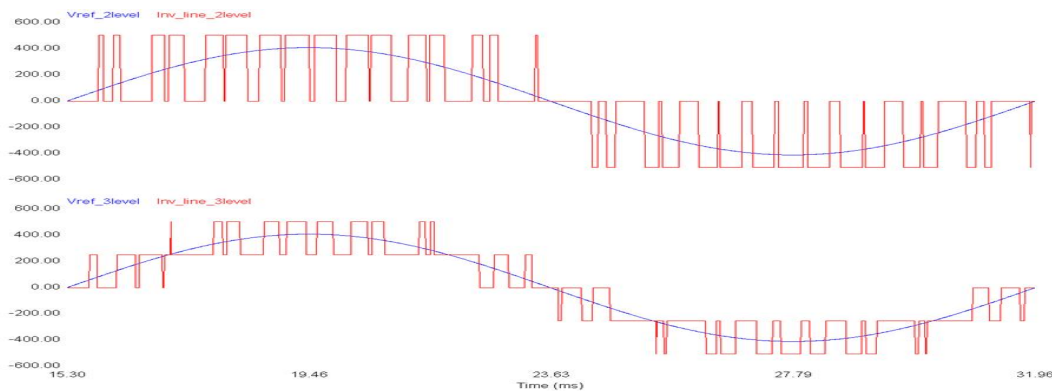
The reason the SCR rectifiers can not be switched faster is because the thyristors are turned on by a gate signal, but turned off by natural commutation (zero crossing of the AC input sine wave) or by a snubber circuit. If used properly with a digital signal processor and a Field Programmable Gate Array, the IGBT switching can be controlled to minimize the harmonics normally produced by a converter, thus eliminating the input harmonic filter.

As stated above, the problem exists with the UPS efficiency. If the IGBT converter is turning on and off in the kilo-hertz range, and the IGBT inverter is turning on and off in the kilo-hertz range, the switching losses will quickly add up creating a less efficient UPS.

**Inverter Section:**

Most manufacturers have recognized the importance of using IGBTs in the UPS inverter. The faster switching capabilities of the IGBT, if controlled properly, will result in a less distorted sine wave and will offer better response to various steps in the output loads and improved compatibility with downstream static transfer switches.

The IGBTs are fired in a series of pulses, which are used to invert the DC from the converter (or batteries) into a clean sine wave (refer to figure 7). Since the pulses are not continuous, high frequency noise is generated from the inverter. The high frequency noise and harmonic content on the output side of the UPS is filtered using an output filter and an output isolation transformer.



**Figure 7: IGBT Switching 2-level (top) and 3-level (Bottom)**

In addition, the isolation transformer on the output of the UPS provides a means to re-establish a neutral ground bond for the downstream distribution.

## **The Mitsubishi 9900 series transformerless UPS systems**

As mentioned earlier, there are many different factors that need to be considered when designing a transformerless UPS system. Ideally, the UPS should be designed with minimal losses throughout the conversion processes (high efficient UPS). This was one of the design goals for the 9900 series UPS. After researching the available power conversion technologies, it was concluded that the three-level topology offered the most benefits while improving the reliability of the system.

The three-level topology reduces the switching losses associated with IGBTs. The result is a more efficient True On-Line Double Conversion UPS system that maintains this higher level of efficiency at loads as low as 10% on the UPS system (reference “**The Power of Green: Mitsubishi 9900A Series High Efficiency True On-Line Double Conversion Uninterruptible Power Supply (UPS)**”).

Adding to the efficiency improvements of the 9900 series is the reduction of the filtering requirements. The input current harmonics of the 9900 is controlled to less than 3% at 100% load without the use of an input harmonic filter. Only a small EMI filter is required for the input of the UPS. By eliminating the input harmonic filter, generator compatibility issues due to harmonics and leading power factor are eliminated.

On the output, since the Three-Level Topology generates pulses that more closely resemble a sine-wave (see figure 7), the output filter is also minimized. The combination creates a highly reliable and efficient True On-Line Double Conversion UPS system. Reducing the size of the UPS filters and eliminating the transformer will also reduce the size and weight of the UPS system and increase the efficiency.

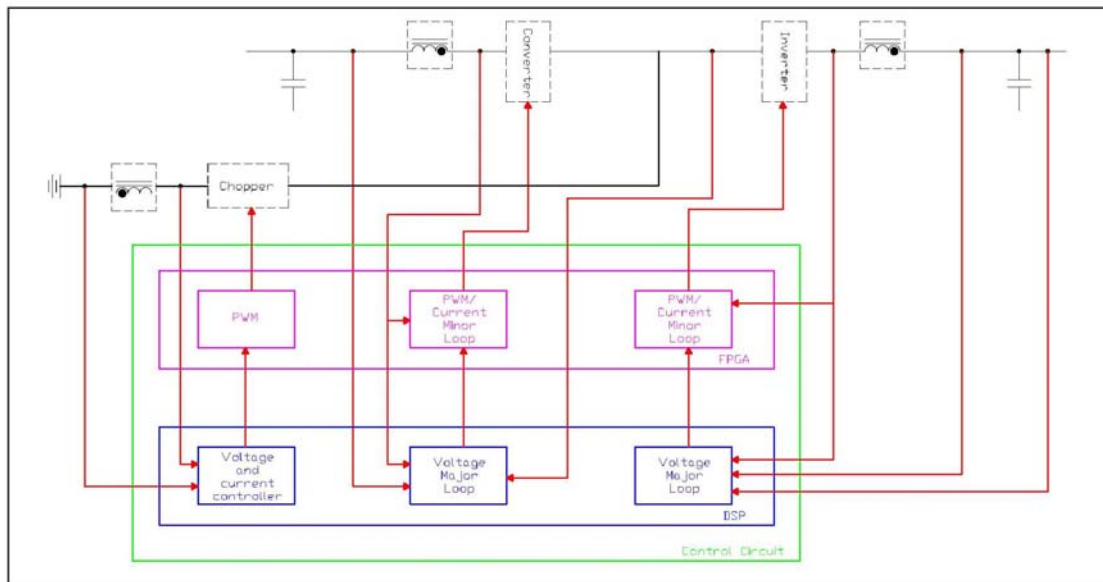
To further enhance the improvements in technology, the 9900 series UPS systems are designed with the newest, most advanced generation of Mitsubishi designed IGBTs. Most manufacturers are still using the second and third generation insulated gate bipolar transistors. Mitsubishi UPS systems are using fourth and fifth generation IGBTs which offer better efficiencies, improved reliability and a lower gate voltage.

Although these are all great benefits for the customer, the UPS control techniques and the UPS response to different types of faults that can occur must now be considered.

### **Control System**

Switching the IGBTs faster is of great benefit, but more important are the control techniques used for the gate signal. The Mitsubishi 9900 series UPS utilizes a high speed Digital Signal Processor (DSP), Application Specific Integrated Circuit (ASIC) and Field Programmable Gate Array (FPGA) for control.

As shown in the block diagram of the control circuit, Figure 8, the 9900 series UPS uses a minor current control loop with a major voltage control loop to provide a precise response to various conditions imposed on the UPS.



**Figure 8: Block diagram of the Mitsubishi Control circuit for a UPS**

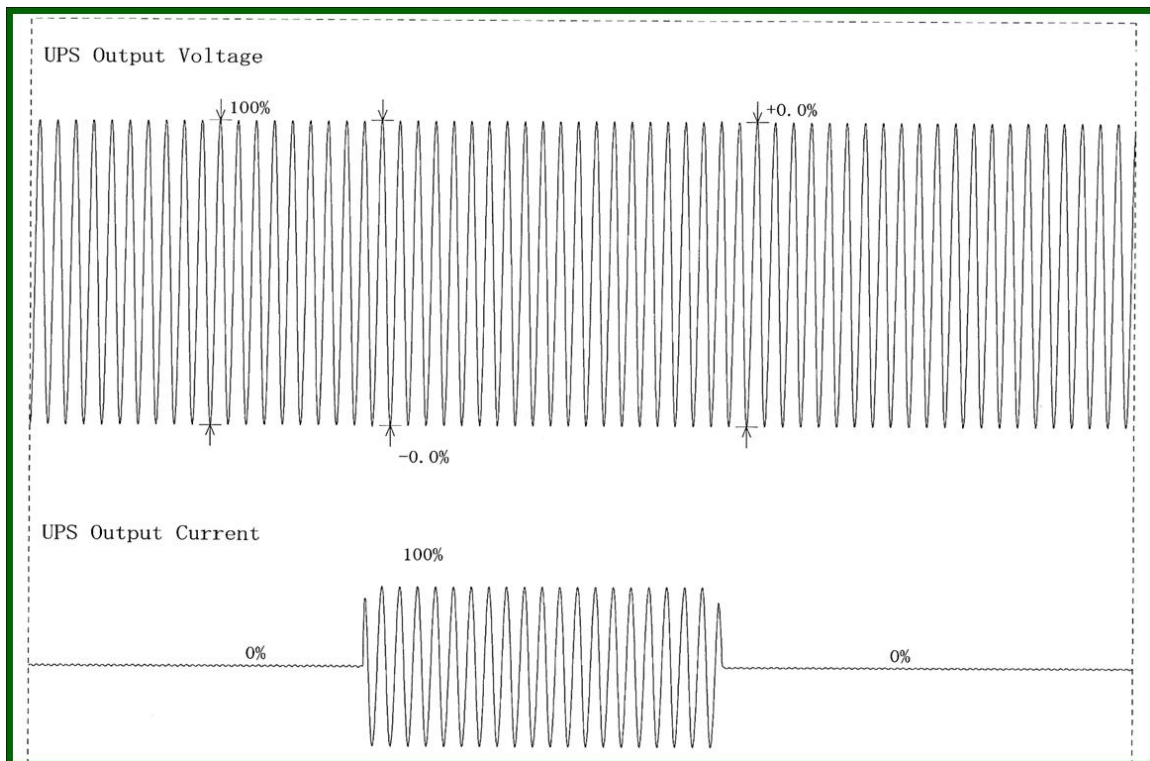
Data from the voltage major control loop is collected and evaluated in the digital signal processor (DSP). The field programmable gate array (FPGA) is used to collect information provided by the DSP in addition to comparing the currents from the current minor control loops. Application specific programming in the FPGA processes the information and provides a switching sequence to compensate for the specific scenarios the load presents.

The multiple feedback control loop allows the UPS logic to quickly detect changes in current in addition to detecting deviations to the voltage allowing for more precise control of the IGBT switching. By using the DSP and the FPGA, which have samplings rate greater than 48 kHz (800 times per cycle), the switching sequence of the IGBTs can be manipulated to provide complete control of the power conversion processes.

In the event a fault occurs (including short circuits) which produces currents exceeding the current limits of the UPS (input or output), the control circuit will immediately stop firing the IGBTs and initiate the opening and closing of the contactors. On the converter section, the input contactor will open and the UPS will operate from the battery source. On the inverter, the UPS will initiate a transfer to bypass to allow the bypass current protection to clear the fault.



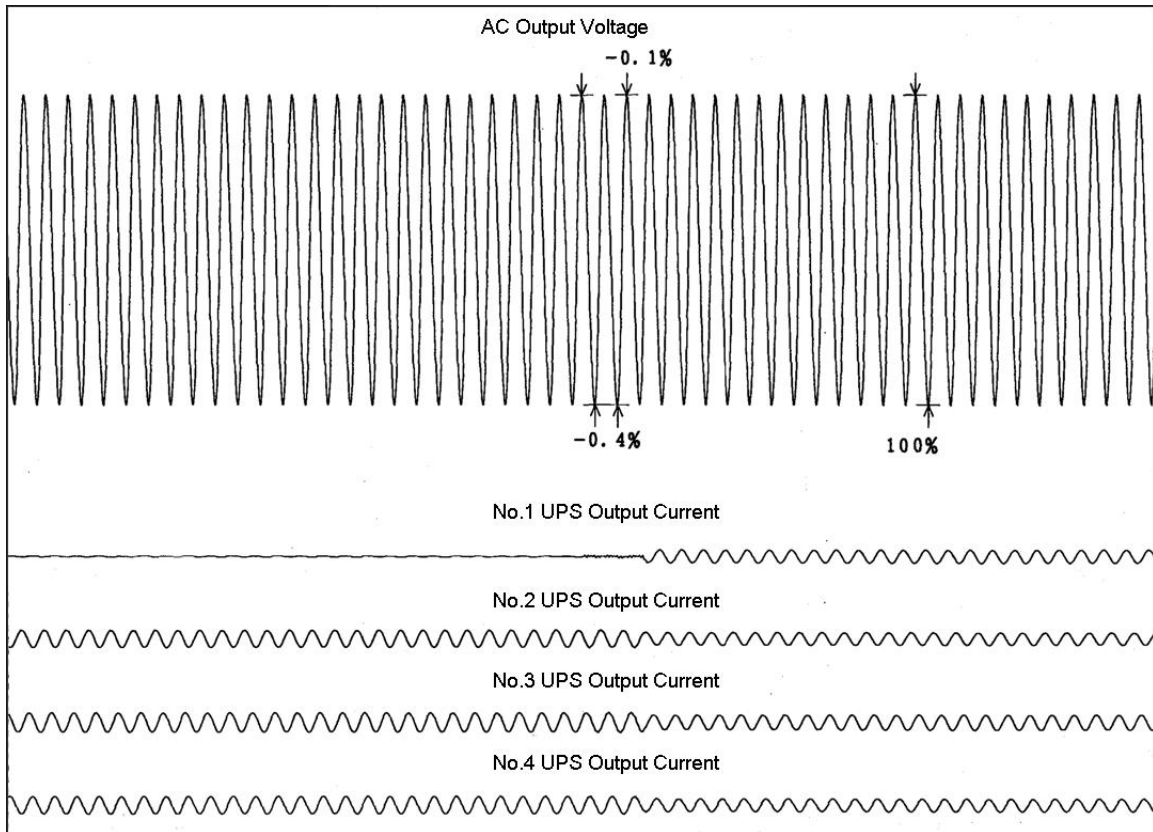
With minimal voltage distortion, the UPS will support any currents that do not exceed the limits of the system, including downstream inrush currents. For example, the UPS inverter can support 0% to 100% step loads on the UPS output while maintaining a voltage with less than 2% deviation (See Figure 9). Since the converter section is also controlled using the same logic, the converter can support the same step loads to the input of the inverter. Therefore, the UPS does not require power from the battery system to perform this step load.



**Figure 9: 100% step load on a 9900 series UPS without batteries**

#### **Control in Multi-Module applications:**

The 9900 series UPS is capable of multiple module configurations (MMS), up to eight kVA matched units in parallel. For all multi-module 9900 series UPS systems, single modules are used without any changes. The same logic is used in each UPS in the multi-module configuration. For a multi-module system, redundant Cat 5e cables are used to connect the DSP and the FPGA of each UPS together. Therefore, the control logic will be looking at its own minor and major control loops, and also the information from the other UPS control loops, to match the output of each UPS on the critical bus. The result is a multi-module system which can instantaneously share load while maintaining clean, reliable, regulated and uninterrupted voltage on the critical bus (refer to figure 10). Since the 9900 series multi-module configuration is used with individual single module UPS systems, the control logic is completely redundant.

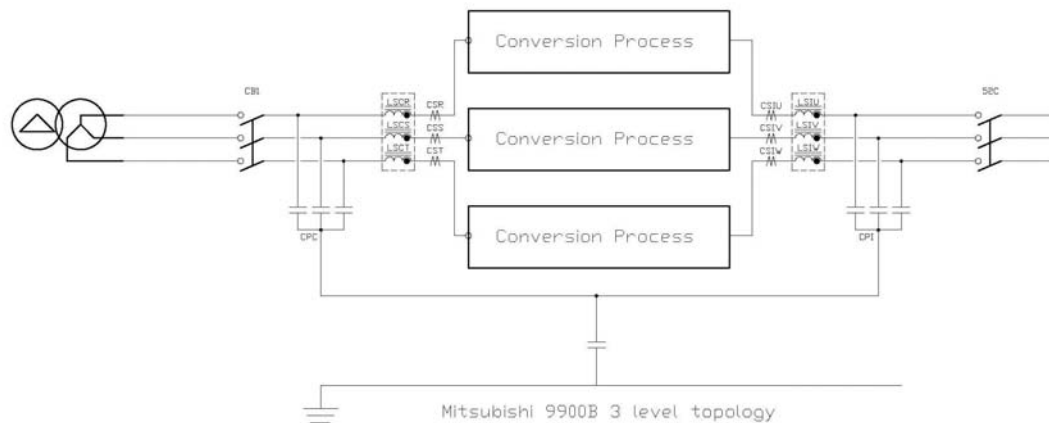


**Figure 10: MMS system with (1) module added to the parallel bus**

### **Virtual Neutral**

Line-to-line noise produced by the high frequency switching inside the UPS system is easily filtered using the small input and output filter of the UPS. However, high frequency line-to-neutral components are not suppressed due to an absence of a common connection between the three phases (neutral connection).

To filter these components, the 9900 series UPS uses a virtual neutral as shown in figure 11, which is created by connecting the common point of each of the filter capacitors to a common point. By virtue of this connection, the common mode harmonics are passed through the virtual neutral of the UPS system.

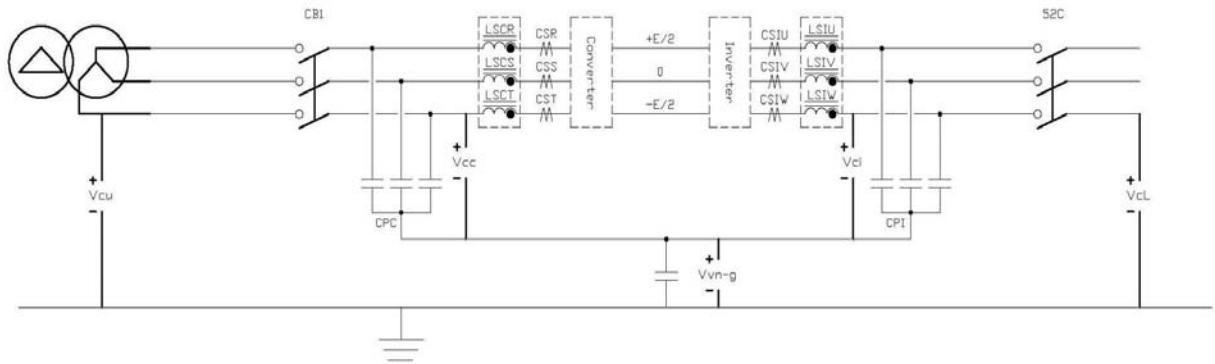


**Figure 11: The 9900 series Virtual Neutral**

In addition to the input connection, the virtual neutral is also tied to the common point of the output filter, where the common mode harmonics are cancelled by the output of the inverter, as shown in Figure 11. During battery operation, the input contactor for the UPS system (CB1) is opened and the common mode harmonics are eliminated from the equation.

The potential of the Virtual Neutral is derived from the three phases on the input. A capacitor is added between the system ground and the virtual neutral. This capacitor, under normal conditions, will have minimal potential across the terminals and minimal current, as the potential of the virtual neutral and the system ground is the same.

As shown in Figure 12 (including the following calculations), confirmation can be made that the output phase voltage referenced to ground will be the same as the output phase voltage referenced to the virtual neutral. The input common mode harmonics are introduced through the Virtual Neutral, but cancelled by the output common mode harmonics.



The voltage  $V_{vn-g}$  is monitored and will be approximately zero  
 To determine the voltage  $V_{cL}$ , the following equation will be used:  

$$V_{cL}(\sin\omega t) = V_{cu}(\sin\omega t) - V_{cc}(\sin\omega t + k\sin 3\omega t) + V_{ci}(\sin\omega t + k\sin 3\omega t)$$

$$V_{cL}(\sin\omega t) = (V_{cu} - V_{cc})(\sin\omega t) + (V_{ci} - V_{cc})(k\sin 3\omega t) + V_{ci}(\sin\omega t)$$
 Since  $V_{vn-g}$  is approximately 0,  $V_{cu} - V_{cc}$  is 0 and this part cancels  

$$V_{cL}(\sin\omega t) = (V_{ci} - V_{cc})(k\sin 3\omega t) + V_{ci}(\sin\omega t)$$
 When  $V_{ci}$  and  $V_{cc}$  are in sync, the third harmonic cancels  
 Therefore,  $V_{cL}(\sin\omega t) = V_{ci}(\sin\omega t)$  confirming the input and the output are at the same potential to ground.

**Figure 12: Virtual Neutral with the output voltage to ground reference calculations**

### Fault Conditions

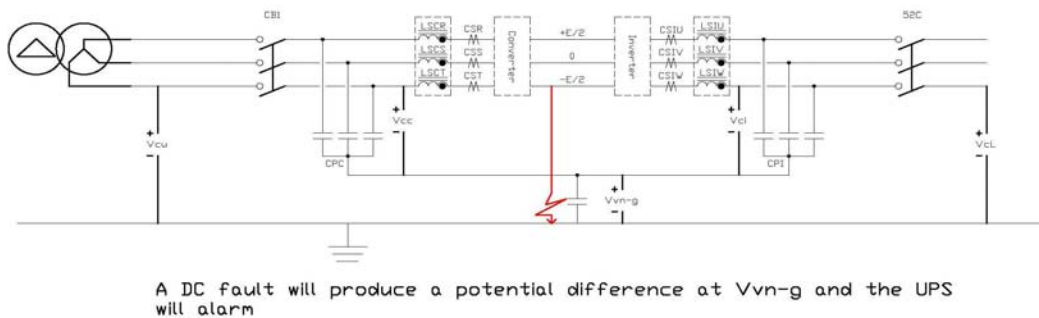
The 9900 UPS system is monitoring fault conditions in multiple ways (voltage differences, current flow and current limiters) and will detect these faults depending on the installation of the system, the configuration of the distribution system and the conditions of the fault.

As mentioned above, if a fault condition occurs on the output of the UPS which produces a large amount of current, the UPS system current minor loop, current limiter and the FPGA will detect the instantaneous over-current. The PWM will then stop firing the IGBTs in the inverter and transfer the system to bypass so the bypass over-current protection can clear the fault (Figure 16). In addition, during an output short circuit, the output voltage will try to collapse. The voltage major control loop with the DSP along with the FPGA will maintain the voltage at first. If the current from the short circuit extends beyond the capabilities of the inverter logic to maintain proper voltage regulation, the DSP and the major control loop will sense a collapse in the output voltage and the system will detect an instantaneous overload.

The same would apply to a fault on the utility side of the UPS system. The converter logic will sense an immediate drop in voltage and the FPGA will stop firing the IGBTs in the UPS converter going immediately to battery operation.

**DC Ground Fault Conditions:**

If a DC Ground fault occurs as in Figure 13, the potential of the system ground will be different than the potential of the Virtual Neutral. This potential difference will be detected by the UPS system and viewed as a safety hazard. The UPS will alarm on a DC Ground Fault condition. The circuit is also being monitored by the chopper circuit logic to detect improper voltages and current levels.

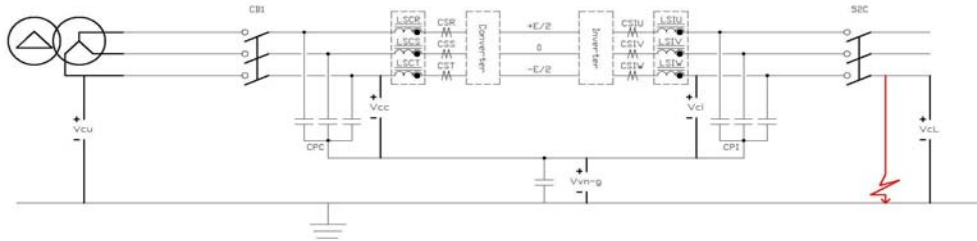


**Figure 13: DC Ground Fault**

**Ground Fault Detection**

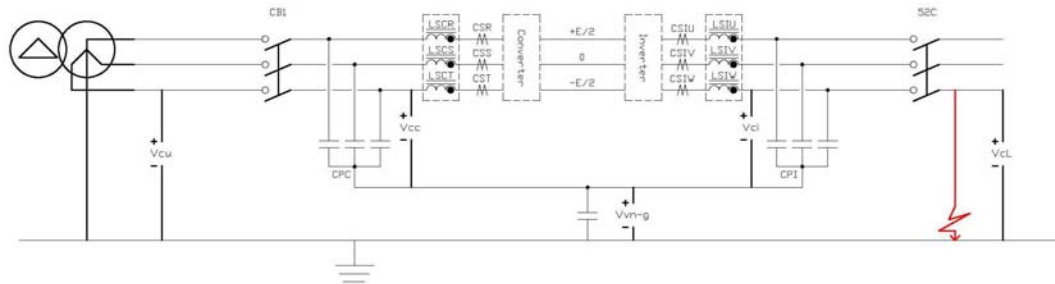
As shown in Figure 14, if the utility source for the UPS is not grounded (no neutral-to-ground bond), the presence of a ground fault will present a potential difference between the UPS Virtual Neutral and the system ground. Therefore, the fault will be detected by the UPS.

As shown if Figure 15, if the utility source for the UPS is grounded (neutral-to-ground bond is installed), the presence of a ground fault will result in a second connection to ground and will produce zero sequence currents. These zero sequence currents will be detected by the UPS.



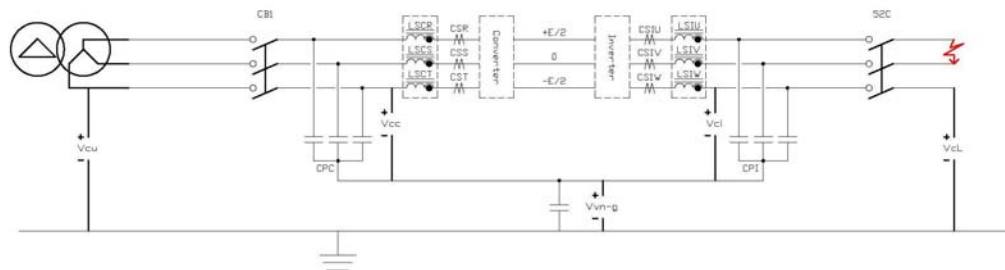
A Phase to Ground fault when the upstream transformer is not grounded will produce a potential difference at  $V_{vn-g}$  and the UPS will alarm

**Figure 14: Ungrounded Phase-to-Ground Fault**



A Phase to Ground fault when the upstream transformer is grounded will produce high amounts of current in the inverter phases and will be detected by the UPS logic.

**Figure 15: Grounded Phase-to-Ground Faults**



A Phase to Phase fault will produce high amounts of current in the inverter phases and will be detected by the UPS logic.

**Figure 16: Phase-to-Phase Faults**

### Summary:

The 9900 series UPS is a high efficiency True On-Line Double Conversion transformerless UPS designed specifically for large power applications. It uses an IGBT converter section with advanced control circuitry to eliminate common mode harmonics and leading power factor issues with the upstream generators. The minor and major control loop used with the Digital Signal Processor and the Field Programmable Gate Array for the IGBT inverter results in precise control of the output voltage for maximum coordination with downstream Power Distribution Units and Static Transfer Switches. The Virtual Neutral allows the UPS logic to monitor all types of faults including system ground faults to offer maximum protection for critical loads.

The result is a UPS which can deliver reliable output power to your critical load with minimal footprint while saving the customer money through an efficiency of greater than 96% at 100% load. The 9900 is available in sizes ranging from 72 kW to 750 kW (SMS) and up to 3750 kW (MMS).

### References:

**“The Power of Green: Mitsubishi 9900A Series High Efficiency True On-Line Double Conversion Uninterruptible Power Supply (UPS)”** by Dean Richards and Junichiro Onishi